

# Montana

## Heating & Cooling Buyers Guide



An Introduction to Choosing Your New  
Home's Heating and Cooling System

This document was produced by the  
National Center for Appropriate Technology.

Introduction	1
The Cost of Space Heating	3
Climate Responsive Design	4
System Design	6
System Commissioning	9
HVAC Contractor Certification	11
HVAC System Options	
● Efficiency Ratings	12
● Forced air Systems	13
● Boilers	18
● Combination Systems	18
● Ductless Heat Pumps	19
● Cooling Equipment	21
Other Important Design Issues	
● Duct Design and Installation Best Practices	22
● The Importance of Resident Education	27



Reducing a building's energy use is the best protection against an uncertain energy future. Regardless of where energy comes from or what its future price, using less is better. By building efficient envelopes (walls, roofs, and floors) the amount of heating and cooling energy required will be minimized. More efficient building envelopes may also reduce the size of the heating and cooling system. Today's high-efficiency heating and cooling systems are engineered and installed to deliver more comfort, improved indoor air quality, and quieter operation. This guide identifies key factors that



Source: ENERGY STAR New Homes Program promotional brochure

homebuyers, designers, and builders should consider when selecting heating and cooling systems appropriate for a particular home. For smaller more energy efficient homes there are alternatives to the traditional central forced air space conditioning system. This guide is introductory in nature and does not include detailed system sizing and design information required to achieve a high performance heating and cooling system.

The ENERGY STAR New Homes program was created to help designers and builders achieve an energy efficient and comfortable home. ENERGY STAR New Homes represents a “best practice” for residential heating, ventilation, and air

---

conditioning (HVAC). For more information about the ENERGY STAR New Homes refer to the program website at <http://www.energystar.gov> and select “New Homes.”

*A Note about Terminology:* **HVAC** is an acronym that stands for “heating, ventilation, and air conditioning.” This guide is focused primarily on residential heating and cooling. Home mechanical ventilation is dealt with in more detail in a companion publication titled “Montana Residential Mechanical Ventilation.”

Mechanical ventilation is critical for a safe comfortable home. Whole house mechanical ventilation is also now a code requirement. Some mechanical ventilation systems are integrated with the forced air distribution systems. While these integrated systems will be mentioned this guide, their treatment will be minimal.

An HVAC system must first be designed. Then the system must be installed. A critical, but often overlooked, third step in the process is commissioning. Commissioning of HVAC systems is important to assure that the system has been installed as designed and is operating properly. That is why the ENERGY STAR New Homes program requires specific post-installation tests and quality assurance inspections. Such commissioning is good practice for all new homes.

Proper duct design and installation is also important to achieve best results in comfort, efficiency, and durability. For example, ducts should be installed within the building thermal envelope to save energy. When ducts are located outside the thermal envelope it suggests a lack of planning and coordination on the part of designers and HVAC contractors.



## The Cost of Space Heating

In Montana space heating energy costs are typically far greater than space cooling costs. The energy costs associated with any particular heating system depends on a number of factors. First, the cost of the fuel or energy source, which varies over time, is critical. The second factor to consider is the efficiency with which the fuel or energy source is converted to heat. Finally the efficiency of the distribution system also impacts the total system efficiency. For example, a high efficiency forced air distribution system with electronically commutated motors (ECM) has a distribution efficiency of about 90%. ECM motors are more efficient than standard air handler fan motors. A standard efficiency furnace, without an ECM motor, has a distribution efficiency of about 70%. Systems without ductwork or piping are assumed to have a distribution efficiency of 100% but may not provide the more uniform comfort provided by ducted or piped distribution systems.

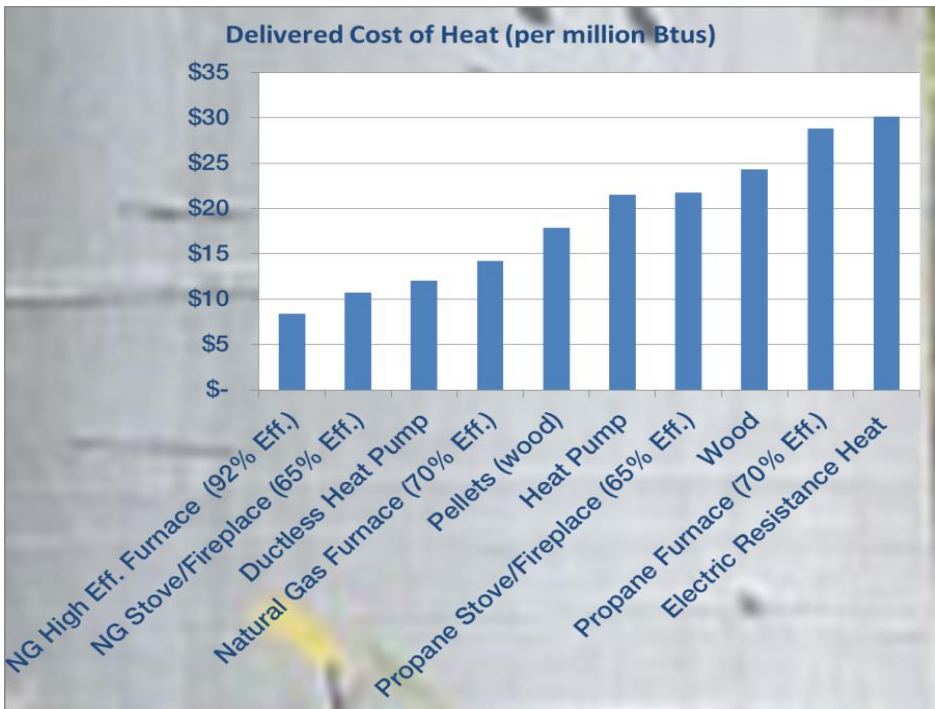

Heating System Type	Unit	BTUs Per Unit	Cost Per Unit	Unit Cost (per million btu's)	System Efficiency	Distribution Efficiency	Combined Efficiency	Delivered Cost (per million Btus)
Natural Gas High Eff. Furnace	Therm	100,000	\$0.70	\$6.95	92.00%	90.00%	83%	\$8.39
Natural Gas Stove/Fireplace	Therm	100,000	\$0.70	\$6.95	65.00%	100.00%	65%	\$10.69
Ductless Heat Pump	kWh	3,413	\$0.10	\$30.18	250.00%	100.00%	250%	\$12.07
Natural Gas Furnace	Therm	100,000	\$0.70	\$6.95	70.00%	70.00%	49%	\$14.18
Pellets (wood)	Ton	16,000,000	\$200.00	\$12.50	70.00%	100.00%	70%	\$17.86
Heat Pump	kWh	3,413	\$0.10	\$30.18	200.00%	70.00%	140%	\$21.56
Propane Stove/Fireplace	Gallon	92,000	\$1.30	\$14.13	65.00%	100.00%	65%	\$21.74
Wood	Cord	12,000,000	\$175.00	\$14.58	60.00%	100.00%	60%	\$24.31
Propane Furnace	Gallon	92,000	\$1.30	\$14.13	70.00%	70.00%	49%	\$28.84
Electric Resistance Heat	kWh	3,413	\$0.10	\$30.18	100.00%	100.00%	100%	\$30.18

Source: Spreadsheet by the Northwest Energy Efficiency Alliance, energy cost values by NCAT

The preceding graph and table compares the cost of delivered heat for several fuel and heating system types. This information is approximate and based on energy costs in the fall of 2015. The estimated cost of delivered heat includes the efficiency of the heating equipment and the distribution efficiency. For most home occupants the comfort provided by the heating and distribution system is at least as important as the cost of delivered heat. The preceding graph and table does not consider installation cost of the heating or distribution system.

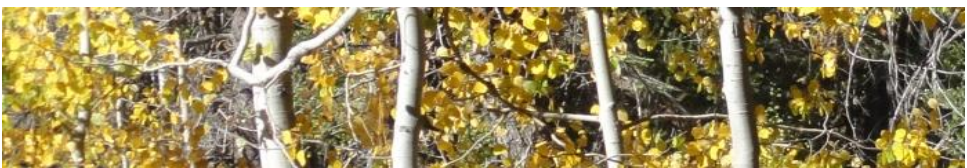

## Climate Responsive Design

Solar energy is a hot topic today. But when solar is mentioned, most people think of photovoltaic (PV) panels mounted on the roof to produce electricity. Many homebuyers, designers, and builders don't realize the energy savings potential of building shape and orientation. These concepts are commonly referred to as passive design, solar tempering, or climate responsive design.

---

## Lot Orientation and Home Site Planning

Designers can use building orientation to take advantage of the sun's natural heat. By facing the long side of a home to the south and the short sides to the east and west, the building will capture solar heat in the winter and block solar gain in the summer. The ideal orientation would be to face the home's long side directly south but it can be oriented up to 30 degrees away from due south and

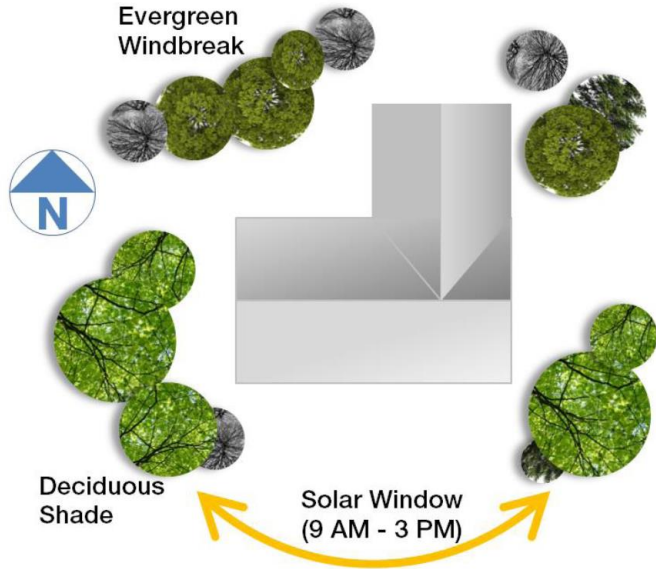

### Climate Responsive Design Site Planning

lose only 5% of the potential solar heat. It is important to increase south-facing window area. A simple rule of thumb is that if the south-facing window area exceeds 10% of conditioned floor area, the home requires thermal storage mass to limit high summer interior temperatures. A study done in the Pacific Northwest by the Bonneville Power Administration estimated solar home space-heating savings between 10% and 20%. To minimize overheating during spring and fall, designers should limit the amount of west-facing glass.

## Windows and Overhangs

When positioning buildings to get the maximum solar benefit, overhangs can help manage heat gain and glare. Overhangs also provide protection from rain, hail, and the effects of overheating and ultraviolet radiation on siding and windows. Overhangs may take the form of eaves, porches, awnings, pergolas, or trellises. Overhangs should be sized to account for differences in sun angles,

---

elevation, window height and width, wall height above the window, and amount of shading desired based on time of day and time of year. Free and low-cost computer programs are available for sizing overhangs.

Windows should be selected to manage the quantity of heat loss and solar gain. In the heating-dominated cold climate of Montana, it is preferable to use windows with a lower U-factor and a higher solar heat gain coefficient (SHGC). The U-factor is a measure of heat transfer. The lower the U-factor the better the window performs at stopping heat flow. The SHGC defines how much of the sun's heat will pass through the glazing in the interior. The lower the SHGC the less solar heat the window transmits. The Montana energy code requires a window U-value of 0.32 or lower but no SHGC is specified.

In the Montana climate many residential space conditioning systems do not include cooling. There are design techniques that can eliminate the need for cooling in some homes. Those techniques include proper building orientation, proper window location, design for natural ventilation, and provisions to shade windows and walls. There is insufficient space in this publication to detail solar and natural cooling design strategies. Rare today is the new home that has been designed with these common sense features.



## System Design

HVAC design impacts a home's construction costs, comfort, air quality, durability, and energy efficiency. The importance of proper HVAC design is often underestimated. There are three major steps to designing an HVAC system.

### **Step 1. Calculate the heating and cooling loads**

Accurate heating and cooling load calculations are critically important for HVAC system design. Load calculations dictate the size of the HVAC system needed. The consequences of choosing the wrong-sized system include: noisy operation,



discomfort, a failure to maintain proper moisture control, and the longevity of the system.

A home's heating and cooling loads depend on a number of factors including the climate, house size, house orientation, tightness of the building envelope, and the thermal characteristics of the envelope. Heating load is the maximum amount of heat likely to be lost from the home in a single hour during the year. Cooling load is the maximum number of Btu's likely to be added to the home in a single hour during the year. *Air Conditioning*

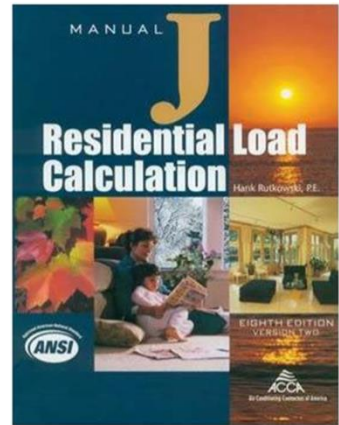

*Contractors of America (ACCA) Manual J* provides a procedure that includes the major variables that can affect a home's comfort level. *Manual J* calculates heating and cooling loads so that the system will maintain design comfort conditions 97.5% of the time based on long term daily average temperatures. Most critically the *Manual J* procedure calculates loads for each room in the house. The Montana energy code requires that *Manual J*, or an equivalent methodology, be used when calculating building loads.

Most available furnaces are oversized for a small energy efficient house. The smallest available furnaces from major U.S. manufacturers are rated at about 40,000 Btu per hour or more. Over the past 30 years, building envelopes have become tighter and better insulated, but U.S. furnace manufacturers haven't adjusted. Installing furnaces that are larger than necessary can result in comfort complaints. In such houses the central area thermostat will be satisfied but the bedroom at the end of a long duct run is still cool. Small furnaces, even when available, can be more expensive. This has led energy efficient home builders to look for alternatives to the central forced air system.

## **Step 2. Select equipment that meets calculated loads**

*ACCA Manual S* provides a reliable standard process for selecting heating and cooling equipment. *Manual S* picks up where *Manual J* leaves off. It lays out a fairly simple procedure for selecting equipment based on the design loads. But

for air conditioning equipment it the selection process is more complicated. The Montana energy code requires that *Manual S*, or its equivalent, be used when selecting heating and cooling equipment.

Many experienced HVAC designers estimate that a *Manual J* calculation takes about 30 to 60 minutes for an average home, using the measurements from construction drawings. *Manual S* calculations require an additional 15 to 30 minutes. A single calculation can work for multiple uses of the same plans.

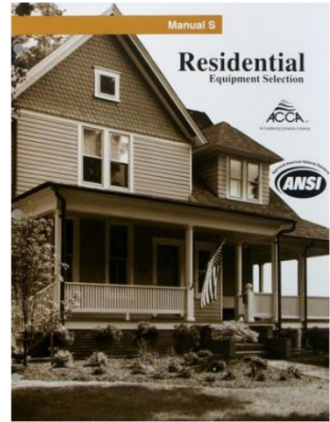

### Step 3. Design the duct system

For central forced air systems the third step is to design a duct system that moves air from the heating and cooling equipment to the rooms in the house, and then from the rooms back to the air handler. In a central forced air system proper airflow is needed to deliver or remove the correct amount of heat from each room. Factors that influence duct system design include: duct length, duct diameter, duct type, duct turns, and other components such as filters.

*ACCA Manual D* provides a reliable standard process for duct design but is not required by code. For more information about duct design and installation refer to the section on Duct Design and Installation later in this document under Related Design Issues section.



## System Commissioning

“Commissioning” is the term used to describe testing the HVAC equipment to determine if it has been installed and is operating properly. You may hear the phrase “commissioning, testing, and balancing” to describe this process, but the single word “commissioning” includes all three functions. Commissioning provides verification that the building’s HVAC equipment and components interact properly. Following are the most important elements of the HVAC commissioning process:

**HVAC controls.** HVAC controls need to be checked. These may include thermostat setback settings and in some homes outdoor temperature reset controls for boilers.

**Forced-air ductwork.** Commissioning forced air ductwork includes:

- Visual inspection of joints and duct sealing
- Visual inspection of the duct insulation
- Duct tightness test
- Verification of airflow at each supply register
- Verification of return-air pathways from every room that has a supply register



Sealing air ducts is required by code and an important step in the installation process. HVAC professionals should seal ducts at the connections to air inlets and registers to prevent conditioned air from seeping into the walls, ceilings, or floors, which could condense and lead to moisture problems.

The Montana energy code requires a duct tightness test unless all ductwork and the air handler are located in conditioned space. But it is good practice to conduct such test regardless of duct location. In addition to smaller leaks at joints, a duct tightness test will identify if there is an inadvertent joint break in

the ductwork that may have been caused by workers after the duct system was installed and sealed. A duct tightness fan is often referred to as a “duct blaster”. It is good practice to test duct tightness before sheet rock is installed but after installation of the ducts. If the ductwork fails to meet the pressure criteria they can be sealed while they are still accessible. While required by the ENERGY STAR program, HVAC commissioning is not yet common practice.

**Combustion appliances.** It’s important to perform combustion safety checks on all combustion appliances like furnaces and water heaters. All venting ductwork needs to be inspected. If there are any atmospherically vented appliances in the house it is good practice to perform a worst case depressurization test to determine if backdrafting of the appliance is a possibility. The worst-case depressurization test is also called a combustion appliance zone test. Such a test is not required by the Montana code.

*Natural draft* water heaters rely on the buoyancy of hot combustion exhaust. As the hot exhaust gases rises, the draft that is created causes fresh air to enter the draft diverter at the top of the tank. If the air pressure inside the house is lower than the air pressure outside, then a natural draft water heater or furnace can backdraft, and poisonous gases such as carbon monoxide can enter the home.

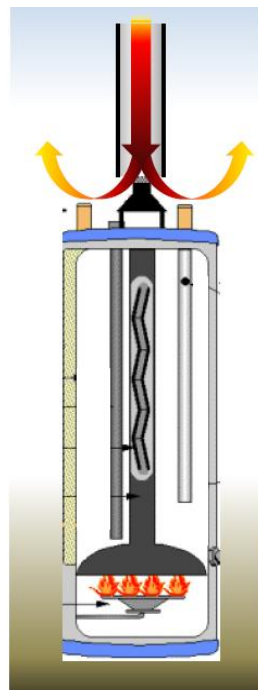

Backdrafting Water Heater

**Air conditioner or air source heat pump.** If the house has central air conditioning, it’s important to verify the equipment’s refrigerant charge and the airflow rate across the cooling coil. According to the ACCA, airflow across the cooling coil should be within the range recommended by the equipment manufacturer and within 15% of the airflow specified by the system design. The ENERGY STAR New Homes program and other “above code” programs require that the air flow at each supply register be measured to verify that it is within

---

20% of the design air flow. The pressure difference between each bedroom and the common areas of the house must be measured to verify that it is no more than 3 Pascals.

**Ground-source heat pumps.** The HVAC systems where commissioning is most critical are ground-source heat pumps (GSHPs). These systems often require five or six different contractors to be involved with the installation. With this many different trades involved it is not uncommon that the system as a whole does not perform properly.

**The ventilation system.** It is important to measure exhaust airflow to determine if required ventilation rates are achieved. System control settings need to be verified. This is especially important if the ventilation system is integrated with a central forced air system. Low return air temperatures, after fresh makeup air is introduced to the return air flow, can result in a cracked heat exchanger.

## HVAC Contractor Certification

Certification of residential HVAC contractors is not new but the ENERGY STAR New Homes program has increased its visibility. Certification is one way contractors can demonstrate their commitment to following best practices in the design, installation, and commissioning of HVAC systems. Arguably, certified HVAC contractors will experience fewer callbacks and complaints by incorporating best practices. HVAC certification is offered by two independent, third-party oversight organizations whose programs have been recognized by ENERGY STAR. Those two organizations and their website addresses are provided below:



Air Conditioning Contractors of America (ACCA) Quality Assured Program

<http://www.acca.org/qa/new-homes>



Advanced Energy HVAC Contractor Credentialing Program

<http://www.advancedenergy.org/portal/hvac/>

## HVAC System Options

Many different appliances can be used to heat a house, including furnaces, boilers, water heaters, heat pumps, and wood stoves. Most traditional space conditioning systems use central forced air to distribute the conditioned air to the rooms of the house. However space conditioning systems that do not require ductwork such as radiant systems, space heaters, and ductless heat pumps are becoming more common, especially for smaller homes. For the best results in comfort, efficiency, and durability, HVAC systems and duct design must be integrated in the overall building design. Builders should work closely with their HVAC engineer to properly size and select the HVAC equipment and ducts. With the advent of air source heat pumps the use of electric furnaces has declined sharply.

### Efficiency Ratings

Following are the most common terms used to define the efficiency of HVAC equipment:

**Annual Fuel Utilization Efficiency (AFUE).** AFUE is the amount of fuel converted to heat at the furnace outlet in proportion to the amount of fuel entering the furnace. This is expressed as a percentage. A furnace with an AFUE of 90 is said to be 90% efficient. AFUE can be calculated for boilers as well as furnaces, and is used for appliances that burn many different types of fuel.

**Seasonal Energy Efficiency Ratio (SEER).** SEER is a measure of air conditioning equipment energy efficiency over the cooling season. It is the total cooling of a central air-conditioner or heat pump in Btu's during the normal cooling season divided by the total electric energy input in watt-hours. Central air conditioning systems use SEER while window units use EER.

**Energy Efficiency Rating (EER).** EER is a rating of a central air conditioner's steady-state



efficiency at 80°F indoors and 95°F outdoors, measured once the air conditioner is running. EER is similar to SEER except it measures the “instantaneous” efficiency rather than the efficiency over an entire season.

**Heating Season Performance Factor (HSPF).** HSPF is a measure of a heat pump’s energy efficiency over the heating season. It is the total heating output of a heat pump, including supplementary electric heat, during the normal heating season in Btu’s divided by the total electricity consumed in watt-hours.

## Forced Air Systems

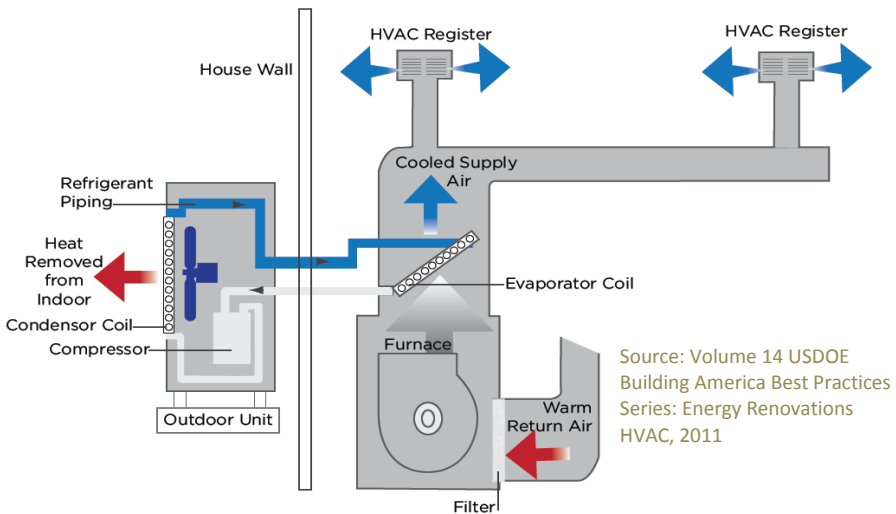

**Forced Air System with Furnace and Air Conditioning**

Forced air systems use ductwork to distribute conditioned air throughout the house. The most common forced air system is a furnace which burns natural gas or propane and includes a fan to blow air through the duct system. Other systems that use ductwork to distribute conditioned air are an air-source heat pump. Instead of a natural gas burner some systems use hot water from an instantaneous water heater to heat the air that is distributed through the duct system. Forced air systems are equipped with a filter that removes airborne particles.

---

## Gas-Fired Furnaces

A high-efficiency ( $\geq 90\%$  AFUE) variable-speed sealed combustion natural gas-fired furnace provides the lowest- cost of delivered heat. Sealed combustion means that an appliance acquires all air for combustion through a dedicated sealed pathway, usually a PVC pipe, from the outside to a sealed combustion chamber, and all combustion products are vented to the outside through a separate, dedicated sealed vent. Sealed combustion appliances eliminate the potential for back-drafting. Sealed combustion furnaces use ECM motors that are more efficient than regular furnace blower motors because they can operate at variable speeds allowing the speed to adjust to the heating and cooling needs of the house. Instead of repeatedly turning on and then shutting off, the variable speed motor runs the blower for longer periods at lower speeds, providing quieter operation, and more even heat and cooling.

Furnaces should not be installed in a vented attic, vented crawl space, or garage where they would waste a lot of heat. Instead they should be installed in a basement mechanical room or a mechanical room near the center of the house.

The usual definition of a *low-efficiency furnace* is one that is less than 75% efficient. Low-efficiency furnaces can no longer be purchased. The federal government requires residential gas-fired furnaces to have a minimum efficiency of 80%.

*Medium-efficiency furnaces* have efficiencies in the range of 80% to

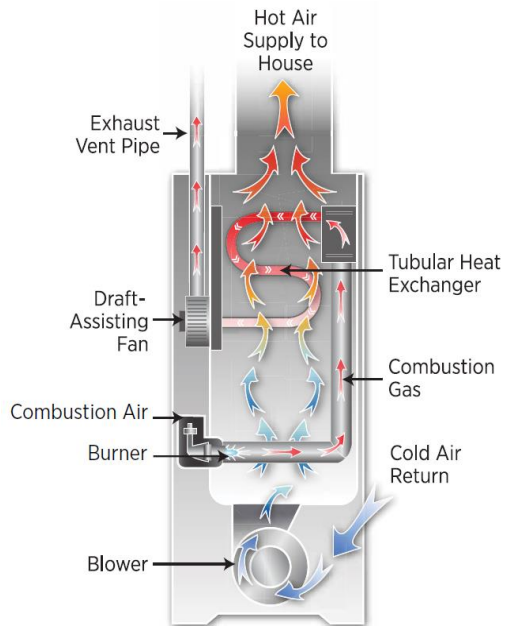

**Mid-Efficiency Gas Furnace**

Source: Volume 14 USDOE Building America Best Practices Series: Energy Renovations HVAC, 2011



82%. *High-efficiency furnaces* are designed to condense flue-gas moisture. *High-efficiency furnaces* are also called “condensing furnaces” and have AFUE ratings between 90% and about 97%. Condensing furnaces require a drain to dispose of the liquid condensate.

The simplest furnaces are *single-stage furnaces* with single-speed fan motors. *Two-stage furnaces* can operate at two different outputs. The higher output is only needed at the coldest times of the year. *Modulating furnaces* include an automatic fuel valve that varies the amount of fuel delivered to the burner.

Condensing furnaces are power-vented and most are “sealed-combustion.” Sealed-combustion furnaces don’t use any indoor air for combustion. An important advantage of a sealed-combustion furnace is that it is much less likely to suffer from backdrafting problems.

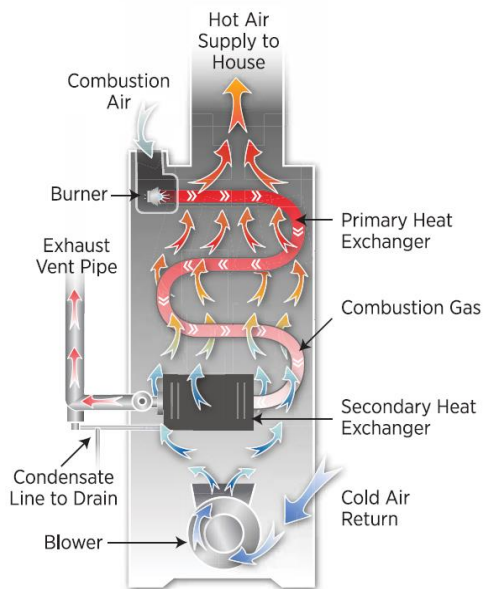

**High-Efficiency Gas Furnace**

Source: Volume 14 USDOE Building America Best Practices Series: Energy Renovations HVAC, 2011

Induced draft furnaces are condensing furnaces but they use indoor air for combustion. Most medium-efficiency furnaces are now induced draft. Induced draft furnaces are less likely than an atmospherically vented appliance to suffer backdrafting but more likely than a seal combustion furnace.

Low return-air temperatures put a furnace at risk of damage and may void the furnace warranty. This could be a problem if the thermostat is setback too low, such as 50°F to 60°F depending on the particular furnace. Low return-air temperatures can also result from bringing make-up air for the mechanical

ventilation system into the return duct without proper low-temperature controls. Low return-air temperatures can contribute to the condensation of corrosive flue gases in the heat exchanger and the ultimate cracking of the heat exchanger.

## Electric Heating and Heat Pumps

Electric resistance heat is used sparingly in today's new homes. It is largely limited to providing supplemental heat in bedrooms and bathrooms in homes equipped with non-ducted space heaters or ductless heat pumps. In Montana, standard air source heat pumps typically use electric resistance back-up heat during very cold periods. Backup natural gas heat is a cost-effective alternative for larger homes.

Heat pumps can be an energy-efficient alternative to propane furnaces and standard air conditioners where natural gas is not available. Heat pumps are often installed as a forced air system. A heat pump operates similar to a refrigerator.

**Air-Source Heat Pump in Heating Cycle**

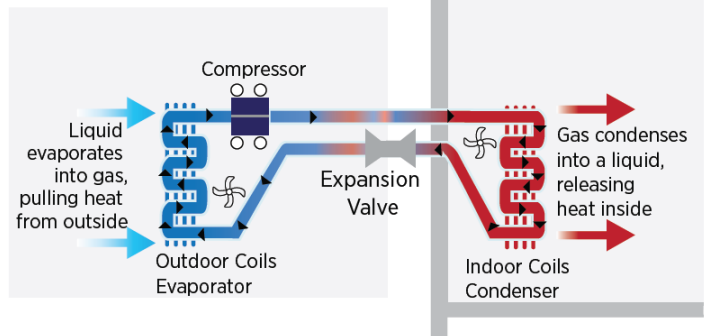

**Air-Source Heat Pump in Cooling Cycle**

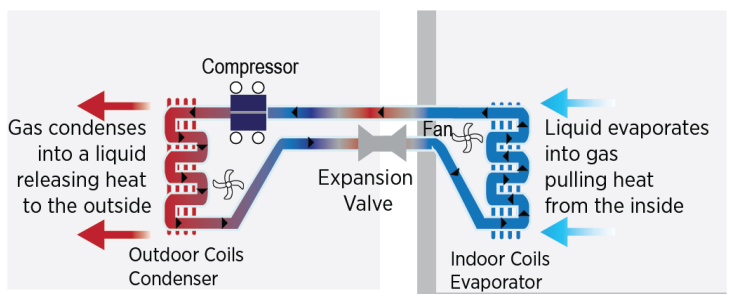

Source: Volume 14 USDOE Building America Best Practices Series: Energy Renovations HVAC, 2011

During the heating season, heat pumps move heat from the cool outdoors into the house; during the cooling season, heat pumps move heat from the house to the outdoors.

Because they move rather than generate heat, heat pumps can provide up to four times the amount of energy they consume. Heat pumps also require the proper thermostat type to function correctly. When choosing a set-back thermostat for a heat pump, choose a model that locks out resistance heating during temperature ramp-up. It is good practice to install an outdoor thermostat to prevent the electric resistance heat from activating unless outdoor temperatures fall lower than the temperature at which the heat pump can provide heat more efficiently than electric resistance backup heat.

### Ground Source Heat Pumps

Unlike air-source heat pumps, which draw heat from the air, ground-source heat pumps use the moderate temperature below ground to achieve high efficiencies.

Geothermal or ground source heat pumps can be very efficient for heating and cooling because they use the constant temperature of the earth as the exchange medium instead

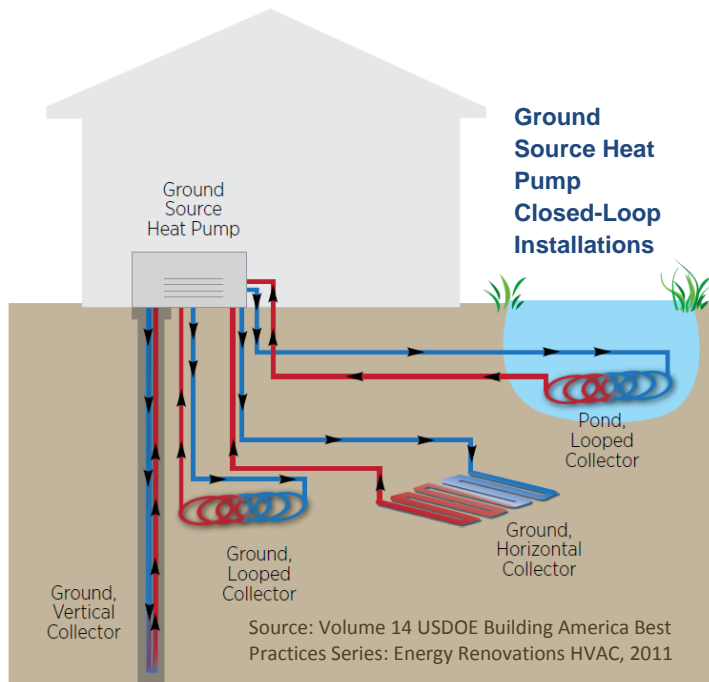

of the outside air temperature. This allows the system to reach fairly high

---

efficiencies (300% or more) on the coldest of winter nights, compared to 175%-250% for air-source heat pumps on cool days. The disadvantages are their initial cost and the need for yard space to install the piping.

In a closed-loop system, piping loops can be laid horizontally, vertically, or looped in the ground or in ponds. These collector options are shown in the diagram in heating mode with fluid circulating to collect heat (red) from the ground, release it to the indoor heat pump through a heat exchanger, and return cooled fluid (blue) to collect more heat.

## Boilers

In the United States many people insist on central air conditioning in their homes for cooling. It's easier to provide whole-house cooling in a home with a ducted system. Once there is a duct system installed for cooling, it's cheaper to install a furnace for winter heating than to install a boiler with a separate distribution system. Boilers remain popular with homebuyers who want the comfort of radiant heat or do not see the need for air conditioning.

Hot water, often termed "hydronic," heating is particularly suitable for space heating in the cold climate in areas where there is no need for air conditioning. The water is usually heated by a natural gas boiler. The hot water is piped through the house which is heated by a radiant floor system or by hot water baseboard units. The Department of Energy Building America program recommends R-15 perimeter insulation, plus R-20 underneath the entire slab. In very well insulated and airtight homes, the benefit of radiant conditioning is significantly reduced as the cost of system installation becomes prohibitive.

## Combination Systems

The term "combination system" usually refers to a system that uses a single water heater to provide both domestic hot water and space heating. The advantage is that only one appliance is required for both water and space heating. By adding an air conditioning coil at the air handler, central cooling can also be provided. Small air handlers with hydronic coils are readily available.

---

Combination systems can be difficult to design and the right combination of contractors to install them may be hard to find. These types of system are often difficult to troubleshoot and maintain. Combination systems based on instantaneous, also called tankless water heaters, can be even more challenging to design properly unless a buffer tank is included. At least one major manufacturer provides complete combination systems using tankless water heaters that are available in 32,000 to 90,000 Btu per hour capacities.

## Ductless Heat Pumps

Ductless heat pumps are a more efficient alternative to standard heat pumps which use ducts and a large blower to distribute the hot or cool air. Ductless heat pumps are sometimes referred to as “mini-split heat pumps” or just “mini-splits.” Ductless heat pumps consist of a single outside compressor/condenser unit connected to one or more wall- or ceiling-mounted indoor air handler units to provide zone heating and cooling without ducts.

The outdoor unit is mounted on a concrete pad outside the house; tubing connects the two units through a small hole in the wall.

Ductless heat pumps provide increased energy savings over standard heat pumps in several ways – because they are ductless and mounted inside conditioned space, there are no losses to the attic or crawlspace or through leaky ducts; they provide zonal heating; and advances in technology in recent years have increased performance to the point that HSPF 12/SEER 26 units are now available.

These high-performing heat pumps also perform at a much wider temperature range than standard heat pumps: some models can operate at an outdoor temperature range of 5°F to 75°F for heating and 14°F to 115°F for cooling,



---

eliminating or significantly reducing the need for backup heat sources in many locations. These ductless heat pumps use an inverter-driven compressor technology coupled with a multi-speed or inverter-driven fan to continuously match the heating/cooling load. Unlike conventional air conditioning/heating systems that stop and start repetitively, the inverter technology adjusts the motor speed, allowing the system to adapt more smoothly to shifts in demand with less temperature variation and much lower energy use. When maximum capacity isn't needed, compressor revolution and power decreases, increasing energy efficiency. Ductless heat pumps provide a range of benefits:

- Reduces energy use by 25%-50% compared to electric resistance heat
- Comes standard with cooling functionality for year-round comfort
- Uses ultra-quiet fans, eliminating noise
- Have built-in air filters that result in improved indoor air quality
- Relatively easy to install

A quality ductless heat pump installation results from attention to details including: tools, installation and homeowner education. Several years ago the Northwest Energy Efficiency Alliance developed a program to displace existing electric resistance heat with energy-efficient ductless heat pumps. Some builders of small energy efficient homes have begun to use these units as the primary space conditioning system.

The main problem with ductless heat pumps is distribution of the conditioned air. This is often referred to as the "cold bedroom" problem. If room-to-room temperature variations are unacceptable, it's possible to design a system with ducted mini-splits but there is a loss of efficiency.

Single-point space conditioning systems such as ductless heat pumps provide no heat to bedrooms and bathrooms except through open doors. U.S. Department of Energy Building America research suggests one possible strategy for providing conditioned air to those rooms when the bedroom doors are closed. Transfer fans can be installed above the bedroom doors but this approach requires coordination between the electrician and HVAC installer to ensure electrical service is provided. Using transfer fans allows heating and cooling energy to

---

reach the bedrooms in lieu of ductwork. Noise and fan control remain challenges. The inability of these systems to meet ACCA standards may be an issue for some installers. Placement of the conditioned air supply register relative to the transfer fan intake can result in some rooms receiving more conditioned air than others. While the use of transfer fans appears promising it is a developing technology.

For information on ductless heat pumps visit [www.NWDuctless.com](http://www.NWDuctless.com).

## Cooling Equipment

The cooling season is shorter in Montana than in many other parts of the country. In a well-designed and well-insulated home, summer heat may be adequately controlled by ventilation combined with climate responsive design to minimize summer solar heat gain. Mechanical cooling options include central air conditioning as part of a central gas furnace forced air system, wall unit air conditioners, and heat pumps. Evaporative cooling is also an option in Montana with our dry climate. Heat pumps are more efficient than standard electric air conditioning and new models of ductless heat pumps offer SEER ratings as high as 26 at a wide temperature range. The EPA reports that 75% of installed air conditioners had the wrong amount of refrigerant when tested. Incorrect refrigerant levels can lower efficiency by 5% to 20% and can cause premature component failure, resulting in costly repairs. Based on these findings, the ENERGY STAR New Homes program requires extensive commissioning for all heat pumps.

A typical single-zone residential forced air system uses a furnace and an air conditioning unit coupled with an air handling unit. The heated or cooled air is blown through ductwork to rooms throughout the house. Unfortunately, often there is almost no provision for air to be returned to the furnace.

## Other Important Design Issues

### Duct Design and Installation Best Practices

Duct design and installation is often taken for granted by builders and homebuyers. The energy code requires that *ACCA Manuals J and S* be used for sizing and selecting the heating and cooling equipment. It is good practice to use *ACCA Manual D* for designing the duct system. The following discussion identifies several design factors that will improve the performance of a central forced air duct system.

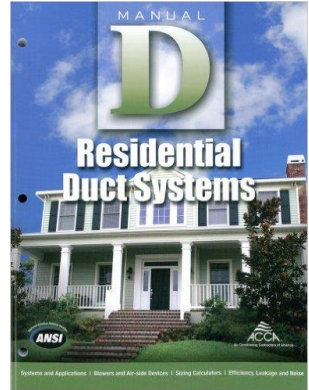

#### **Install ducts inside the thermal envelope.**

Research has shown significant savings results from installing the ducts and air handler in conditioned space. Best practice is to locate the ducts in conditioned space so that any duct leakage that does occur will send air to or draw air from conditioned space. Ducts may be run through open-web floor trusses in a two-story home; through a dropped hallway ceiling in a one-story home; or through a conditioned attic, conditioned crawlspace, or conditioned basement. Ducts should not be located in exterior walls. Atmospherically vented furnaces should be located in an air-sealed and conditioned closet.

Keeping ducts and air handlers inside conditioned space requires that the designer address duct placement early in the design process. The solution to locating all ducts within the conditioned envelope may include use of duct chases or dropped soffits.

An important consequence of locating ductwork or airhandler outside the conditioned space is code required tightness testing. The current energy code allowable duct leakage of 4 cfm per 100 ft<sup>2</sup> of conditioned floor area is a very tight standard. If duct tightness testing is required, locating supply registers under cabinets without a duct boot to the toe kick register becomes a major



---

problem. If the air handler and ducts are located within the thermal envelope no tightness testing is required by code.

**Do not use framing cavities for supply or return ducts.**

The energy code prohibits use of building cavities for supply ducts. Framing cavities like stud bays or panned floor joist spaces are leaky and very difficult to seal. The Montana energy code allows building cavities to be used as return ducts however leaky return ducts can depressurize the combustion appliance zone and potentially cause backdrafting of atmospherically vented water heaters.



Source:  
USDOE  
Building  
Energy  
Codes  
University

**Install branch duct balancing dampers.** Every branch duct running to a register needs a balancing damper. These dampers allow adjustment during the commissioning process to make sure that each room gets the proper air flow.

**Use of galvanized ducts is preferable to flex duct.**

The corrugations in flex ducts cause turbulence that reduces airflow through the duct. It is difficult to install flex duct straight and well supported. Ducts should be as short and straight as possible to minimize friction and to provide maximum efficiency. Whether galvanized or flex ducts are installed they must be supported with a sufficient number of duct hangers to prevent sagging.

**Locate supply registers to reduce length of ductwork.**

Supply registers were usually located near cold outside walls, often under windows, to minimize discomfort from winter air infiltration and cold surface

---

temperature. In today's well insulated tight homes equipped with high-quality windows it is feasible to install supply registers on interior walls. This allows shorter duct lengths and more efficient system operation.

### **Provide return-air pathway.**

Inadequate return-air pathways can create pressure imbalances from indoors to outdoors or room to room that cause problems in a home. Most homes are equipped with supply ducts that deliver conditioned air to every room but often there is no dedicated return-air pathway from each room back to the furnace. It is common for one or two large return-air grilles to be located in the central areas of the home to serve the entire house.

The result of inadequate return-air is room-to-room pressure imbalances that lead to uneven room temperatures, negative pressures in the combustion appliance zone potentially cause backdrafting of atmospherically vented appliances and increased movement of warm humid air into building cavities causing moisture problems in walls and ceilings.

In most new homes, if the bedroom doors are closed, there's no easy way for the air to get back to the return-air grille located in the central zone. As a result, each bedroom becomes pressurized. There are four possible options to solve the pressurized-bedroom problem. Each bedroom needs either a:

**Dedicated return air ducted back to the furnace.** Dedicated return air for each bedroom is becoming more common in some areas. This addresses the room pressurization problem and provides fresh air to all rooms if the mechanical ventilation system is integrated with the air handler. Although solving the problem of pressure imbalances the approach adds cost.



**Door undercuts.** Door undercuts are not recommended by the U.S. Department of Energy Building America program because they are often too small and/or are often eventually blocked by the installation of carpeting. Providing return air with a door undercut is usually not adequate to solve the pressurized bedroom problem because the undercut would be unacceptable large, over one inch for all but the smallest of rooms. Often door undercuts are assumed by the HVAC designer but the trades that install the doors are not under the control of the HVAC contractor.

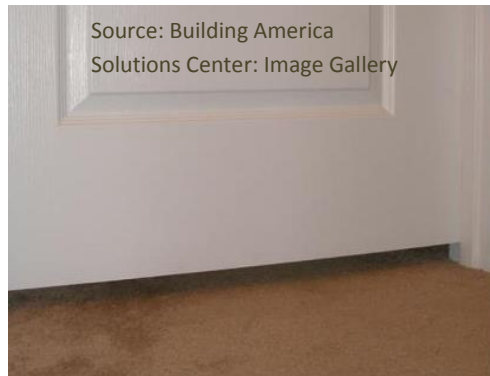

Source: Building America Solutions Center: Image Gallery

**Transfer grille.** A through-the-wall transfer grille connecting the bedroom and the adjacent hallway or

central space can also relieve pressure imbalances. Sound transmission in jump ducts or transfer grilles can be minimized by the use of flex duct, duct lining with sound-absorbent material, a slightly circuitous path, or some combination of these strategies. Through-the-wall transfer grilles are a cheaper solution

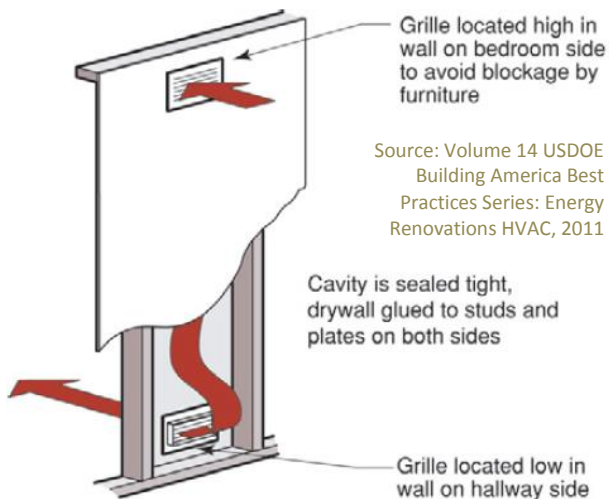

typically suffers from a greater noise problem than crossover ducts. A few new products are available that attempt to address the noise problem.

**Crossover duct.** A crossover duct is also called a “jump duct.” It connects a ceiling grille in the bedroom with a ceiling grille in the hallway. A crossover duct transmits less noise than a through-the-wall transfer grille.

Crossover ducts, if installed in the thermal envelope, will share disadvantages, such as heat loss, with other ducts in located in unconditioned space. It would be best to install crossover ducts only within the thermal envelope or in homes with insulation that follows the roof slope.

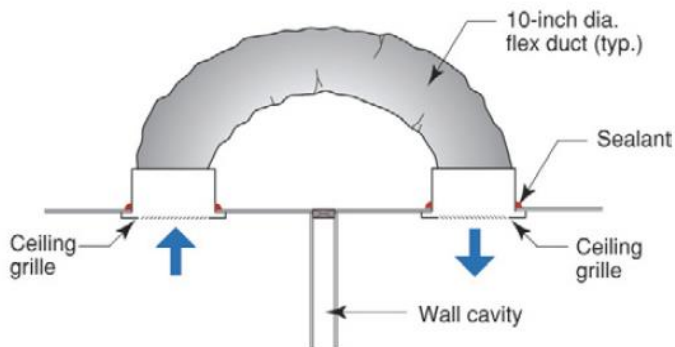

Source: Volume 14 USDOE Building America Best Practices Series: Energy Renovations HVAC, 2011



---

## The Importance of Homebuyer Education

The designer and builder’s job is to provide a house that will keep the occupants safe, comfortable, and healthy. But if the occupants do not understand how to use the HVAC systems properly then the result will be unhappy occupants and poor performing homes. Following are guidelines for how the builder should educate homebuyers:

- Provide a “Homeowner’s Operation and Maintenance Guide”
- Explain and demonstrate HVAC system operation
- Explain and demonstrate system controls
- Emphasize how to use the programmable thermostat properly
- Demonstrate maintenance procedures
- Leave behind instructions on who to contact for future HVAC maintenance and questions



---

**Disclaimer:** This document is only to be used as a general guide. Images of specific manufacturer product lines are not placed as endorsements. The views and opinions expressed in this publication are those of the author do not necessarily reflect those of funders or any state agency.

**References:**

*Volume 12. USDOE Building America Best Practices Series: Builders Challenge to 40% Whole-House Energy Savings in the Cold and Very Cold Climates*, Prepared by PNNL and ORNL, 2011

*Volume 14. USDOE Building America Best Practices Series: Energy Renovations HVAC*, Prepared by PNNL and ORNL, 2011

*Builder's Guide to Cold Climates* by Joseph Lstiburek, Building Science Press, 2006

Building America Program: Bringing Building Innovation to the Market, USDOE  
<http://energy.gov/eere/buildings/building-america-bringing-building-innovations-market>

ENERGY STAR for New Homes Program, USEPA  
[http://www.energystar.gov/index.cfm?c=new\\_homes.hm\\_index](http://www.energystar.gov/index.cfm?c=new_homes.hm_index)

**Reviewing Agencies:**

Montana Department of Labor and Industry  
Montana Department of Environmental Quality



This document was prepared by the  
National Center for Appropriate Technology (NCAT)  
3040 Continental Drive, Butte, Montana 59701  
Dale Horton, Architect, Sustainable Energy Program Manager



Funding for the printing of this publication has been provided through electric Universal System Benefits funds collected from NorthWestern Energy customers.